

Scribing tool ALINOX 431 of aluminium

with mm-graduation, accuracy acc. with DIN 862, measuring beam of aluminium, with straight, slidable hm-scriber 250 x 8 x 8 mm

vernier 1/20 mm

Measuring range	Meas. beam cross section	Foot size	Item No.
500 mm	36 x 9 mm	135x 90x30 mm	624.605
1000 mm	36 x 9 mm	196x120x30 mm	624.610

Tool with wider measuring range upon request.

Spare scribers available:

Item No.	Design	Length
624.615	straight	250 mm
624.620	cranked	250 mm

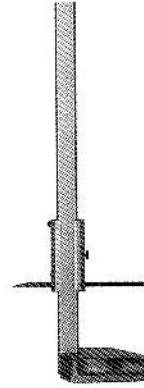

624

Height gauge and marking instrument No. 1814

with exchangeable rule with mm- or shrinkage graduation, chromed.

Rules with two numbers for straight and stepped scribers.

Accuracy acc. to DIN 862, vernier 1/10 mm, dazzling-free reading, reading parts stain chromed. The verniers are screwed on and adjustable. Sliding adjustment over gearwheel and gearrod. The base with hardened pins guarantees a work free of vibrations on the marking plate. Rule height adjustment.

Supply schedule: 1 straight scriber point (not carbide tipped) and 1 rule with mm graduation.

Meas. range mm	Instrument w. basic equipm.	Item No.						
		Shrinkage rules						
		0,5 %	0,8 %	1,0 %	1,25 %	1,5 %	1,75 %	2,0%
600	625.001	625.105	625.108	625.110	625.112	625.115	625.117	625.120
1000	625.002	625.205	625.208	625.210	625.212	625.215	625.217	625.220
1500	625.003	625.305	625.308	625.310	625.312	625.315	625.317	625.320
2000	625.004	625.405	625.408	625.410	625.412	625.415	625.417	625.420

Dimensions and accessories

Meas. range mm	Cross sect. of beam [7] mm	Base Ø mm	Cross sect. of rule [7] mm	Scriber points / Item No.				Dial gauge holder	
				straight		stepped			
				not carb.tip.	carb.tip.	not carb.tip.	carb.tip.		
600/1000	20 x 20	160	12 x 4	8 x 8 x 270	625.531	625.501	625.511	625.521	625.551
1500/2000	40 x 20	280	25 x 5	12 x 10 x 350	625.533	625.503	625.513	625.523	

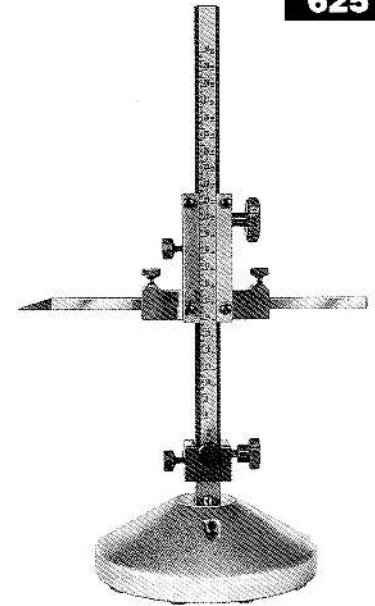

625

Digital height measuring and marking instrument

with built-in shrinkage calculator from 0 to 9,99 % (for two different shrinkage degrees)

Technical data:

Measuring range:	750 mm
Working range:	870 mm
Increment:	0,005 mm
Uncertainty of measurement:	+/- 0,015 mm
Power supply:	NC-accumulator, 4,8 V, 500 mA (for abt. 10 h. op.)

The measuring head has a coarse and fine adjustment and locking feature for marking and is equipped with two dovetail guides.

Scope of supply: Instrument with holder for a long scriber, hard metal scriber (250 mm long), charger and hood. **Item No. 626.001**

Accessories:

Item No.	Description
626.100	universal holder suitable accessories:
626.101	hard metal scribers 68 x 10 x 7 mm
626.102	hard metal scribers 150 x 10 x 12 mm
626.110	standard holder suitable accessories:
626.103	hard metal scribers 250 x 10 x 12 mm
626.104	scriber 300 mm, cranked
626.109	scriber clip for parallel clamping two scribers
626.111	spare charger
626.113	spare protective hood

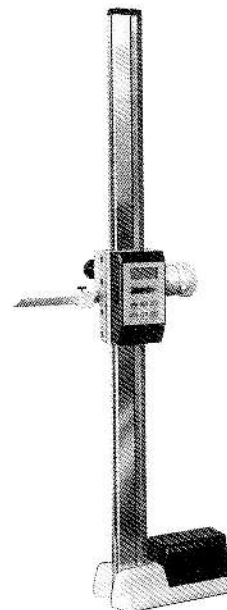

626