

Auxiliary materials and tools for resin working

B) Mixing tools (continued)

Mixing pots of hard paper, PE-coated

Contents	Height	Top dia.	Bottom dia.	Item No.
530 ccm	83 mm	110 mm	90 mm	963.053
750 ccm	109 mm	111 mm	90 mm	963.075
1100 ccm	115 mm	132 mm	110 mm	963.110



963

Mixing pots of polyethylene

reusable, resistant to solvents

Contents	Height	Top dia.	Bottom dia.	Item No.	
				Pot	Lid
180 ccm	72 mm	86 mm	57 mm	963.118	963.119
350 ccm	82 mm	85 mm	72 mm	963.135	963.136
500 ccm	89 mm	103 mm	88 mm	963.150	963.151
860 ccm	113 mm	107 mm	95 mm	963.186	963.187
1620 ccm	144 mm	136 mm	119 mm	963.262	963.263

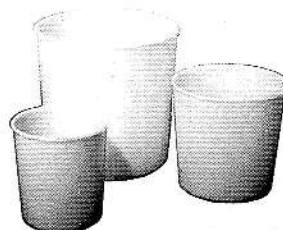

963A

Plastic buckets

without lid, with handle and scale, heavy-duty design

Cap. ltr.	2,5	5	10	12
Top dia. mm	170	200	270	280
Bottom dia. mm	130	150	185	205
Height mm	150	200	240	260
Item No.	137.102	137.105	137.110	137.112



964

Stirrers

- 1) of beech, handle side rounded, 250 x 25 x 4 mm **Item No. 965.001**
- 2) of recycled plastics
solvent-resistant, acid-resistant, can be recycled, reusable, with recesses for the tin rim
255 x 25 x 4 mm **Item No. 965.002**



965

C) Auxiliaries for mould mounting

Mould mounting elements of polystyrene

for easy production of basis-bodies for moulds or gauges (supporting cases).

Save a lot cost against manual production. May be glued with normal adhesive for polystyrene, may be combined in any way.

- 1) **Basic units** **Item No. 966.001**
Each package contains:
72 pcs. of basic elements (part 1) 200 x 200 x 105 mm
100 pcs. of filling plates (part 2) 100 x 100 x 15 mm width
- 2) **Supplementary units** **Item No. 966.002**
Each package contains:
25 pcs. edge profiles, thick type (part 3), 40 x 40 x 500 mm length
25 pcs. cross profiles (part 4), 30 x 30 x 500 mm length
25 pcs. edge profiles, thin type (part 5), 30 x 30 x 500 mm length

We can also supply mounting elements made of aluminium, steel or cast-iron, ready to use.

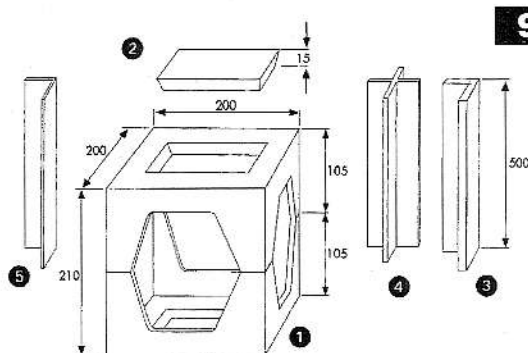

966

Aluminium-honeycomb boards (M-Boards)

lightweight sandwich-boards, honeycombs and sheeting glued together, 0,55 mm thick aluminium sheeting, honeycombs aluminium (d = appr. 6 mm).

extremely lightweight, for tools and gauges
board size 1220 x 2440 mm

Item No.	967.005	967.010	967.020
Thickness	1/2"	1"	2"
Weight (kg/m ²)	4,6	5,8	8,1

Also available: Alu-U-channels for rims, length 3 m

Item No.	967.110	967.120	Item No.	967.200
inside appr.	1"	2"	Alu-angles appr.	50 x 30 x 2 mm

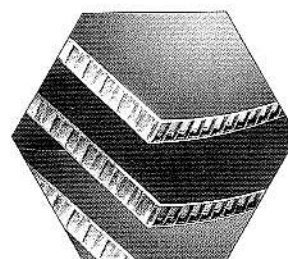

967