

## Combined grinding machines

### 1) Disc-, belt- and roller sanding machine PRC

- small dimensions
- movable
- inclineable grinding tables
- easy tool exchange

**Technical data:**

Disc diameter	300 mm
Oscillation	12 mm
Roller's height	120 mm
Roller's diameter	15 - 45 mm
Belt length	830 mm
Belt width	20 - 40 mm
Motor power	1,47 kW
RpM	1.430 min <sup>-1</sup>

	Disc-	Belt-	Roller-machine
Table dimension	350 x 150 mm	290 x 250 mm	290 x 200 mm
Table inclination	+45° / -30°	+25° / -30°	+35° / -30°

**Standard equipment:**

4 rollers, height 120 mm  
3 belts, length 830 mm

**Accessories:**

Goniometer square  
Rollers, height 120 mm hoch  
Bedplate with wheels, with electroaspirator inside  
Dust recoverer  
Machine lamp 24V

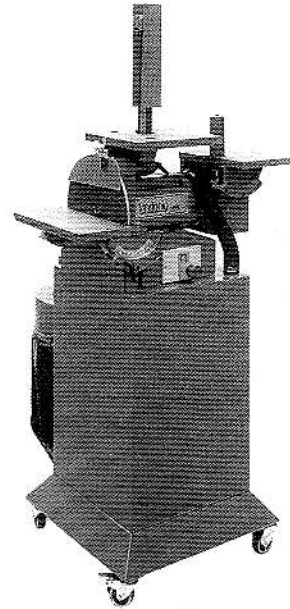

### 2) Disc- and belt sanding machine LGNV 600

- discs of aluminium
- rotation clockwise & counterclockwise
- tables inclineable
- exhaust connection

**Technical data:**

Disc diameter	600 mm
Size disc table	800 x 300 mm
Inclination disc table	+35° / -45°
Belt length	1800 mm
Belts' width	40-60-80 mm
Sanding height	400 mm
Size belt's table	700 x 600 mm

Inclination belt table	+18° / -45°
Motor machine	
- power	1,5 kW
- RpM	1140 min <sup>-1</sup>
Exhausting motor	
- power	0,5 kW
- airflow	600m <sup>3</sup> /h
Exhaust conn. diameter	150 mm

**Accessories upon request:**

enforced motor	2,2 kW
steel disc	600 mm Ø
dust recoverer	
goniometer square	
machine lamp 24V	

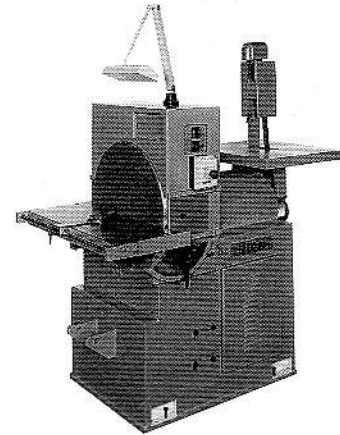

### 3) Disc- and broad-belt sanding machine B 150

- heavy duty quality
  - low noise level
  - inclineable tables
- a) with 1 speed  
b) with 2 speeds

**Technical data:**

Disc diameter	300 mm
Size disc table	300 x 415 mm
Inclination disc table	+45° / -45°
Disc RpM	2400 min <sup>-1</sup>
Belt length x width	1220 x 150 mm

Size belt table	375 x 190 mm
Inclination belt table	+45° / -45°
Belt speed	18 m / sec.
Motor power	1,5 kW
Net weight	120 kg

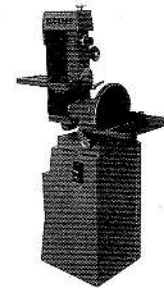

### 4) Table belt sander TBSM 75

may be used both horizontal and vertical

**Technical data:**

Belt length	1000 mm
Belt width	75 mm
Sanding area	300 mm
Belt speed	15 m/sec.
Aspirator conn.	50 mm
Weight	30 kg

Motor 3 phase, curr. 400 V	0,55 kW
alternatively:	
Motor A.C. 230 V	0,55 kW

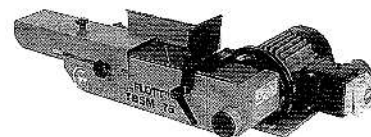

**Delivery contains:**

Machine, one belt grain 80, aspirator connection, switch/plug-combination

TBSM 75 in horizontal position

**Please ask for detailed offers for all machines!**