

## Drilling machines

### 1) Table drilling machine TB P 18 ST R 1

Mandrel speed infinitely variable up to 2400 RpM

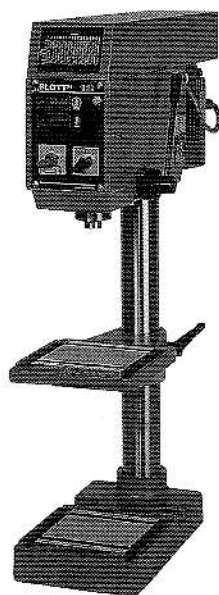

#### Standard equipment:

- Digital speed indication
- Digital drilling depth indication
- Quick setting depth stop
- Speed infinitely variable
- Cable length 1,5 m
- Relay to protect voltage drop
- Switch for rotation clockwise/counterclockwise

Technical data:	
Drill diam. permanent/standard	15 / 18 mm
Mandrel	MK II
Drilling depth	70 mm
Radial range	185 mm
Pillar diam.	70 mm
Table size	240 x 290 mm
Speed indication	digital
Drilling depth indication	digital
Depth stop	quick setting ring
Support	manual
Variation of table height	by rack
Weight	85 kg
Dist. mandrel/table	0 – 360 mm
Motor 3-phase curr. 400 V pole switchable	0,45 / 0,75 kW
Mandrel speed	500 – 2400 RpM infinitely

#### Accessories upon request:

- Machine lamp
- Quick setting drill-chuck B 16,1 – 13 mm
- Conical sticker MK II / B 16

### 2) Drilling machine Typ BM 50 S

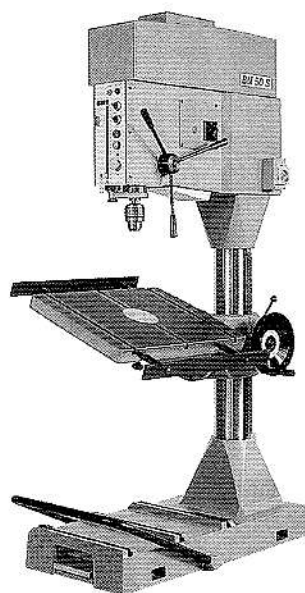

Technical data:	
Depth	500 mm
Lifting of drill-mandrel	225 mm
Lifting of drill-mandrel by pedal	125 mm
Mandrel's speed infinitely variable	280 – 1900 min <sup>-1</sup> / 140 – 1900 min <sup>-1</sup>
Table size	650 x 500 mm
Table may be broadened for	200 mm
Table may be tilt away up to	90°
Table may be moved around the pillar	360°
Diam. of the pillar	∅ 150 mm
T-type slots in the table and bottom plate	12 mm
Chucking cone	MK 3
Drill chuck	3 – 16 mm oder 3 – 20 mm
Motor power	1,1 kW
Voltage standard	3 x 380 V, 50 Hz
Light	40 W
Weight	appr. 500 kg

#### Extra accessories:

- Motor 1,5 kW, 750 RpM
- Mandrel's speed infinitely variable 140 – 1900 RpM, with Motor 1,0/1,6 kW, 750/1500 RpM
- Pedal
- Drill-chuck 3 – 16 mm with sticker
- Heavy-duty drill-chuck 3 – 20 mm, ball-bearing, incl. sticker
- Variation of table height by gearing motor and keyboard control

**Please ask for detailed offers for all machines!**